

A_S-W25 & B_LS-W25 Series

0.25W, FIXED INPUT, ISOLATED & UNREGULATED
DUAL/SINGLE OUTPUT DC-DC CONVERTER

multi-country patent protection RoHS

FEATURES

Small Footprint
1KVDC Isolation
SIP Package
Internal SMD Construction
Temperature Range: -40°C to +85°C
No Heatsink Required
No External Component Required
Industry Standard Pinout
RoHS Compliance

APPLICATIONS

The A_S-W25 & B_LS-W25 Series are specially designed for applications where a group of polar power supplies are isolated from the input power supply in a distributed power supply system on a circuit board.

These products apply to:

- 1) Where the voltage of the input power supply is fixed (voltage variation $\leq \pm 10\%$);
- 2) Where isolation is necessary between input and output (isolation voltage $\leq 1000\text{VDC}$);
- 3) Where the regulation of the output voltage and the output ripple noise are not demanding.

Such as: purely digital circuits, ordinary low frequency analog circuits, and IGBT power device driving circuits.

MODEL SELECTION

B0505LS-W25

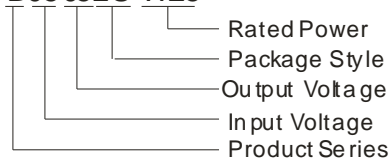

MORNSUN Science & Technology co.,Ltd.

Address: 2th floor 6th building, Hangzhou Industrial District, Guangzhou, China
Tel: 86-20-38601850
Fax: 86-20-38601272
<http://www.mornsun-power.com>

PRODUCT PROGRAM

Part Number	Input		Output		Efficiency (% Typ)		
	Voltage (VDC)		Voltage (VDC)	Current (mA) Max			
	Nominal	Nominal					
B0303LS-W25*	3.3	3.0-3.6	3.3	75.8	62		
B0305LS-W25			5	50	65		
A0505S-W25	5	4.5-5.5	± 5	± 25	62		
A0509S-W25*			± 9	± 13.8	64		
A0512S-W25			± 12	± 10.4	66		
A0515S-W25			± 15	± 8.3	65		
B0505LS-W25			5	50	64		
B0509LS-W25*			9	27.8	65		
B0512LS-W25			12	20.8	67		
B0515LS-W25			15	16.7	65		
A1205S-W25*			12	10.8-13.2	± 5	± 25	62
A1209S-W25*					± 9	± 13.8	63
A1212S-W25*	± 12	± 10.4			64		
A1215S-W25*	± 15	± 8.3			65		
B1203LS-W25*	3.3	75.8			62		
B1205LS-W25	5	50			65		
B1209LS-W25*	9	27.8			66		
B1212LS-W25	12	20.8			67		
B1215LS-W25*	15	16.7			66		
A2405S-W25	24	21.6-26.4			± 5	± 25	63
A2409S-W25*			± 9	± 13.8	64		
A2412S-W25*			± 12	± 10.4	65		
A2415S-W25*			± 15	± 8.3	65		
B2405LS-W25			5	50	63		
B2409LS-W25*			9	27.8	63		
B2412LS-W25*			12	20.8	65		
B2415LS-W25*			15	16.7	65		
B2424LS-W25*			24	10.4	64		

*Designing.

COMMON SPECIFICATIONS

Item	Test conditions	Min	Typ	Max	Units
Storage humidity				95	%
Operating Temperature		-40		85	°C
Storage Temperature		-55		125	
Temp. rise at full load			15	25	
Lead temperature	1.5mm from case for 10 seconds			300	
Short circuit protection*				1	s
Cooling		Free air convection			
Case material		Plastic (UL94-V0)			
MTBF		3500			K hours
Weight			2.1		g

*Supply voltage must be discontinued at the end of short circuit duration.

ISOLATION SPECIFICATIONS					
Item	Test conditions	Min	Typ	Max	Units
Isolation voltage	Tested for 1 minute and 1 mA max	1000			VDC
Isolation resistance	Test at 500VDC	1000			MΩ

OUTPUT SPECIFICATIONS					
Item	Test conditions	Min	Typ	Max	Units
Output power				0.25	W
Line regulation	For Vin change of ±1%	(3.3V input)		±1.5	%
		(Others input)		±1.2	
Load regulation	10% to 100% load	(3.3V output)	12	20	%
		(5V output)	10.5	15	
		(9V output)	8.3	15	
		(12V output)	6.8	15	
		(15V output)	6.3	15	
Output voltage accuracy		See tolerance envelope graph			
Temperature drift	100% full load			0.03	%/°C
Ripple & Noise*	20MHz Bandwidth		50	75	mVp-p
Switching frequency	Full load, nominal input		100		KHz

*Test ripple and noise by "parallel cable" method. See detailed operation instructions at Testing of Power Converter section, application notes.

- Note:
- All specifications measured at $T_A=25^{\circ}\text{C}$, humidity<75%, nominal input voltage and rated output load unless otherwise specified.
 - See below recommended circuits for more details.
 - Dual output models unbalanced load: ±5%.

TYPICAL CHARACTERISTICS

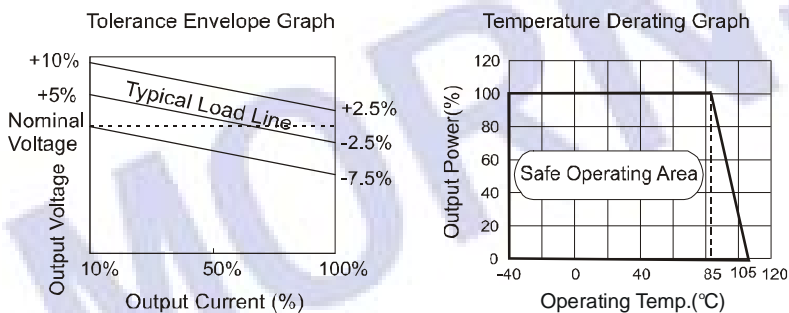

OUTLINE DIMENSIONS & PIN CONNECTIONS

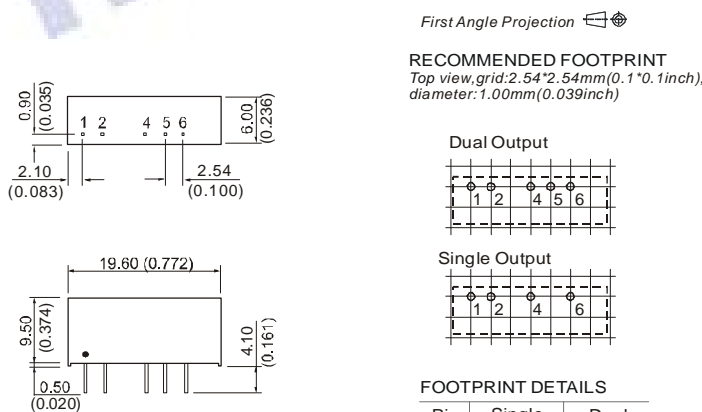

Note:
 Unit:mm(inch)
 Pin section:0.50*0.30mm(0.020*0.012inch)
 Pin section tolerances:±0.10mm(±0.004inch)
 General tolerances:±0.25mm(±0.010inch)

FOOTPRINT DETAILS		
Pin	Single	Dual
1	Vin	Vin
2	GND	GND
4	0V	-Vo
5	No Pin	0V
6	+Vo	+Vo

APPLICATION NOTE

Requirement on output load

To ensure this module can operate efficiently and reliably, During operation, the minimum output load is not less than 10% of the full load, and that this product should never be operated under no load! If the actual output power is very small, please connect a resistor with proper resistance at the output end in parallel to increase the load.

Overload Protection

Under normal operating conditions, the output circuit of these products has no protection against overload. The simplest method is to connect a self-recovery fuse in series at the input end or add a circuit breaker to the circuit.

Recommended circuit

If you want to further decrease the input/output ripple, an "LC" filtering network may be connected to the input and output ends of the DC/DC converter, see (Figure 1).

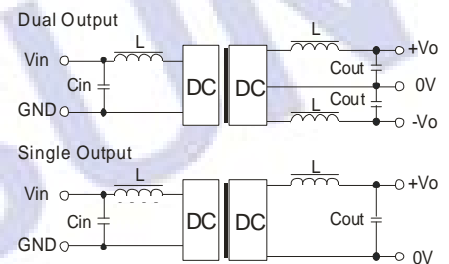

(Figure 1)

It should also be noted that the inductance and the frequency of the "LC" filtering network should be staggered with the DC/DC frequency to avoid mutual interference. However, the capacitance of the output filter capacitor must be proper. If the capacitance is too big, a startup problem might arise. It's not recommended to connect any external capacitor in the application field.

Output Voltage Regulation and Over-voltage Protection Circuit

The simplest device for output voltage regulation, over-voltage and over-current protection is a linear voltage regulator with overheat protection that is connected to the input or output end in series (Figure 2).

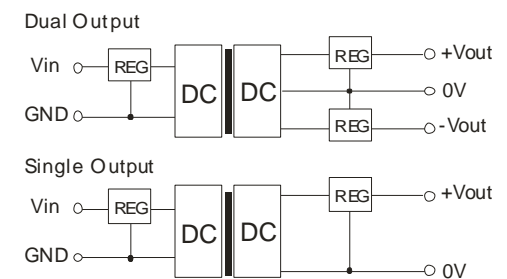

(Figure 2)

No parallel connection or plug and play.