

KRB_S-1W Series

1W, WIDE INPUT REGULATED NON-ISOLATED SINGLE OUTPUT MINIATURE SIP PACKAGE

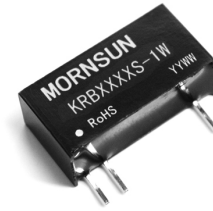

multi-country patent protection **RoHS**

FEATURES

- High Efficiency
- Temperature Range:-20°C to +71°C
- Single Output
- UL94-V0 Package
- No External Component Required
- No Heat sink Required
- Industry Standard Pin out
- MTBF>1,000,000 hours

APPLICATIONS

The KRB_S-1W Series are specially designed for applications where a wide range input voltage power supplies a regulated output from the input power supply in a distributed power supply system on a circuit board.

These products apply to:

- 1) Where the voltage of the input power supply is wide range;
- 2) Where the regulation of the output voltage and the output ripple noise are demanding.

MODEL SELECTION

KRB0712S-1W

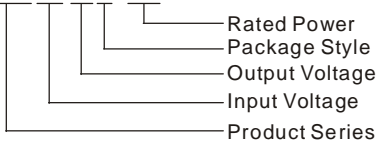

MORNSUN Science& Technology co.,Ltd

Address: 2th floor 6th building, Huangzhou Industrial District, Guangzhou, China
 Tel: 86-20-38601850
 Fax: 86-20-38601272
[Http://www.mornsun-power.com](http://www.mornsun-power.com)

PRODUCT PROGRAM

Part Number	Input			Output			Efficiency (% Typ)	Package Style
	Voltage (VDC)			Voltage (VDC)	Current (mA)			
	Nominal	Range	Max*		Max	Min		
KRB0305S-1W	3.3	2.7-5.4	5.4	5	200	20	80	SIP
KRB0309S-1W				9	110	11	81	SIP
KRB0312S-1W				12	83	9	82	SIP
KRB0503S-1W	5	4.0-7.2	7.2	3.3	300	30	83	SIP
KRB0512S-1W	5	3.6-7.2	7.2	12	83	9	83	SIP
KRB0515S-1W				15	67	7	83	SIP
KRB0524S-1W				24	42	5	80	SIP
KRB0703S-1W	7.2	5-8	10	3.3	300	30	83	SIP
KRB0705S-1W				5	200	20	84	SIP
KRB0712S-1W				12	83	9	85	SIP
KRB0715S-1W	7.2	6.4-8.4	10	15	67	7	86	SIP
KRB0724S-1W				24	42	5	82	SIP
KRB1203S-1W	12	9-14	14	3.3	300	30	80	SIP
KRB1205S-1W				5	200	20	85	SIP

*If Input voltage above specified may cause permanent damage to the device.

OUTPUT SPECIFICATIONS

Item	Test conditions	Min	Typ	Max	Units
Output power	See below products program	0.1		1	W
Output Voltage accuracy	Refer to recommended circuit		±1	±3	%
Load regulation	From 10% to 100% load		±0.5	±0.75	
Line regulation	Input Voltage From Low to High		±0.2	±0.5	
Temperature drift (Vout)	Refer to recommended circuit			0.02	%/°C
Ripple+Noise*	20MHZ bandwidth		80	150	mVp-p
Switching frequency	100% load, nominal input voltage	100		500	KHz

*Test ripple and noise by "parallel cable" method. See detailed operation instructions at Testing of Power Converter section, application notes.

Note:

1. KRB0305S-1W Output Voltage Accuracy: ±5%(max)
2. All specifications measured at T_A=25°C, humidity<75%, nominal input voltage and rated output load unless otherwise specified.
3. See below recommended circuits for more details.

COMMON SPECIFICATION					
Item	Test Conditions	Min	Typ	Max	Units
Storage humidity				95	%
Storage temperature		-55		125	°C
Operating Temp.		-20		71	
Lead temperature	1.5mm from case for 10 seconds			300	
Temp. rise at full load			15	25	
Cooling	Free air convection				
Case material	Plastic(UL94-V0)				
MTBF		1000			K hours
Weight			3		g

TYPICAL CHARECTERISTICS

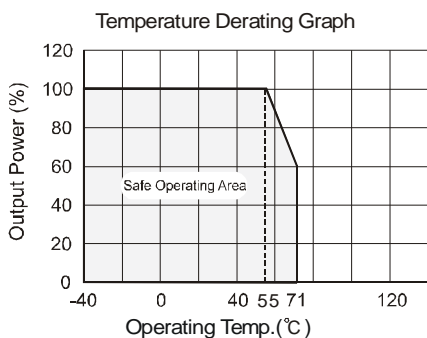

OUTLINE DIMENSIONS

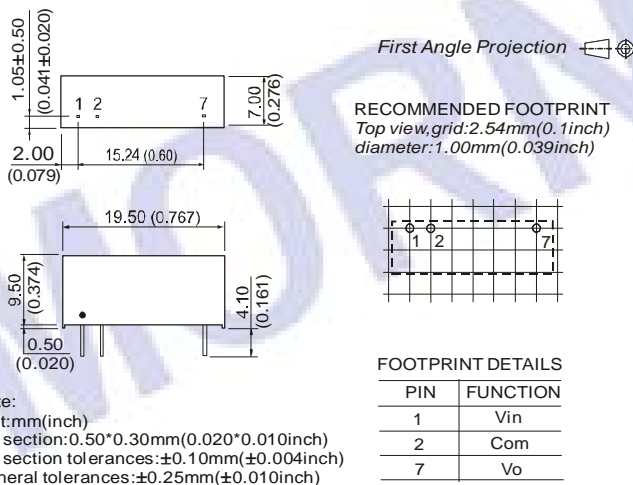

APPLICATION NOTE

Requirement on Output Load

To ensure this module operate efficiently and reliably, a minimum load is specified for this kind of DC/DC converter in addition to a maximum load (namely full load). During operation, make sure the specified range of input voltage is not exceeded, the minimum output load is not less than 10% Of the full load, If the actual load is less below the specified minimum load, the output ripple of this type of DC/DC converter may increase drastically.

If the actual output power from the load in your circuit is very small, please connect a resistor with proper resistance at the output end to in parallel to increase the load, or use our company's other products with a lower rated output power.

Recommended Circuit

This Series have been tested according to the following recommended testing circuit before leaving factory. (Figure 1) .

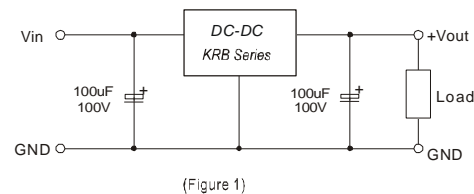

If you want to further decrease the input/output ripple, you can increase capacitance properly or choose capacitors with low ESR. However, the capacitance should not be too high(Table 1).

External Capacitor Table (Table 1)

Cin	Cout (normal temp.)	Cout (-20~+71 °C)
100uF	100uF (electrolytic capacitor)	47uF (tantalum capacitor)

Input Current

When it is used in unregulated power supply, be sure that the fluctuating range of the power supply and the rippled voltage do not exceed the module standard. Input current of power supply should afford the startup current of this kind of DC/DC module. (Figure 2)

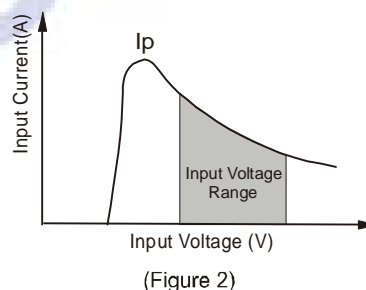

The products cannot be used in parallel.